

# 4. QUICK START

## 4.1. Quick Start ATyS p Frame B3 to B5 (125 A to 630 A)



QUICK START EN 125A - 630A

# ATyS p

Motorised Source Changeover Switch  
Automatic Transfer Switching Equipment

### Preliminary operations

Check the following upon delivery and after removal of the packaging:

- Packaging and contents are in good condition.
- The product reference corresponds to the order.
- Contents should include:
  - Qty 1 x ATyS p
  - Qty 1 x Emergency handle and fixing clip
  - Quick Start instruction sheet

### Warning

**⚠ Risk of electrocution, burns or injury to persons and / or damage to equipment.**

This Quick Start is intended for personnel trained in the installation and commissioning of this product. For further details refer to the product instruction manual available on the SOCOMEC website.

- This product must always be installed and commissioned by qualified and approved personnel.
- Maintenance and servicing operations should be performed by trained and authorised personnel.
- Do not handle any control or power cables connected to the product when voltage may be, or may become present on the product, directly through the mains or indirectly through external circuits.
- Always use an appropriate voltage detection device to confirm the absence of voltage.
- Ensure that no metal objects are allowed to fall in the cabinet (risk of electrical arcing).

Failure to observe good engineering practises as well as to follow these safety instructions may expose the user and others to serious injury or death.

**⚠ Risk of damaging the device**

- In case the product is dropped or damaged in any way it is recommended to replace the complete product.

### Accessories

- Bridging bars and connection kits.
- Control voltage transformer (400VAc -> 230VAc).
- DC power supply (12/24Vdc -> 230VAc).
- Mounting spacers to raise the product x 10mm.
- Phase barriers.
- Terminal shrouds / Terminal screens.
- Auxiliary contacts (Additional).
- Padlocking in 3 positions (I - 0 - II).
- Lockout accessories (RONIS - EL 11 AP).
- Door escutcheon frame.
- ATyS D20 Interface (remote control / display unit).
- RJ45 cable for ATyS D20 => ATyS p.
- Voltage sensing kit.
- Current transformers.
- Plug-in optional modules: RS485 MODBUS communication, 2 inputs/2 outputs, Ethernet communication + RS485 JBUS/MODBUS gateway, Analogue outputs, Pulse outputs.

For further details refer to the product instruction manual under chapter "Spares and Accessories"



[www.socomec.com](http://www.socomec.com)

To download, brochures, catalogues and technical manuals:  
<http://www.socomec.com/en/documentation-atys-p>

Printing informations: 1 color Black. White paper 90g/m<sup>2</sup>.  
Printing size: 420x297. Final size 210x297. This page visible first.  
CORPORATE HQ CONTACT:  
SOCOMECSAS, 1-4 RUE DE WESTHOUSE, 67235 BENFELD, FRANCE



Non contractual document.  
Subject to change without notice.

541 999 E - 10/16 - EN

**Installation and Commissioning**

**STEP 1**  
Cabinet / Back Plate Installation

**STEP 2**  
Power Terminal Connections

**STEP 3**  
COMMAND / CONTROL terminal connections

**STEP 4**  
Power SUPPLY and ATS Controller Terminal Connections

**STEP 5**  
CHECK

**STEP 6**  
PROGRAMMING  
A - Software  
B - Keypad

**STEP 7A**  
AUT Mode  
(Automatic Control)

**STEP 7B**  
AUT Mode  
(Remote Control)

**STEP 7C**  
Manual Mode

**STEP 7D**  
Padlocking Mode

**STEP 4** **Power Supply, Sensing and Control wiring (ATS Controller)**  
 Connect the product with a cable of section of 1,5 to 2,5 mm<sup>2</sup>.  
 Screw M3 - Tightening torque: min.: 0.5 Nm - max.: 0.6 Nm

**ATS Power Supply Input II**  
Power supply II - L/N  
Power supply II - N/L  
208-277 VAC ±20%:  
50/60 Hz

**ATS Voltage Sensing Input Source supply II**  
S II - Phase / Neutral  
S II - Phase  
S II - Phase  
575 VAC (ph-ph) max  
S II - Neutral / Phase  
332 VAC (ph-n) max

**Programmable Inputs**  
To opt. Module/Common  
Prog. Inputs (208-209)  
To opt. Module positive

**Genset Start/Stop Signal**  
NC  
Common  
NO

**Current Transformer incoming cable connections**

**Slots for optional modules**  
See on the back "Optional modules"

**ATS Power Supply Input I**  
Power supply I - L/N  
Power supply I - N/L  
208-277 VAC ±20%:  
50/60 Hz

**ATS Voltage Sensing Input Source supply I**  
S I - Phase / Neutral  
S I - Phase  
S I - Phase  
575 VAC (ph-ph) max  
S I - Neutral / Phase  
332 VAC (ph-n) max

**ATS Module Control Inputs (Programmable)**

**ATS Module Output Contact (Programmable)**

**Remote interface**  
RJ45 - to ATyS D20

Recommended to use SOCOMEC Voltage Sensing Kit (refer to ATyS p accessories for details)

## STEP 1 Installation

Caution: Ensure that the product is installed on a flat rigid surface.

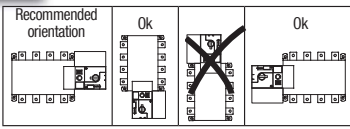

Door cut-out for front panel.

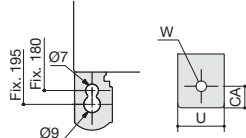
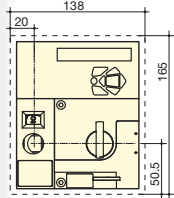

Dimensions in mm.

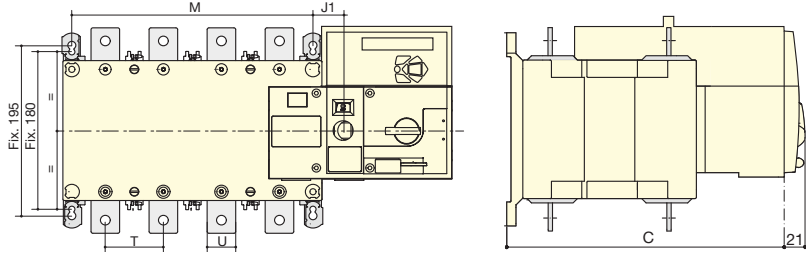

	125 A		160 A		200 A		250 A		315 A		400 A		500 A		630 A	
	3 P	4 P	3 P	4 P	3 P	4 P	3 P	4 P	3 P	4 P	3 P	4 P	3 P	4 P	3 P	4 P
J 1	34	34	34	34	34	34	35	35	35	35	35	35	34	34	34	34
M	120	150	120	150	120	150	160	210	160	210	160	210	210	270	210	270
T	36	36	36	36	36	36	36	50	50	50	50	50	65	65	65	65
C	244	244	244	244	244	244	244	244	244	244	244	244	320	320	320	320
U	20	20	20	20	20	20	25	25	35	35	35	35	32	32	45	45
W	9	9	9	9	9	9	11	11	11	11	11	11	13	13	13	13
CA	10	10	10	10	10	10	15	15	15	15	15	15	20	20	20	20

## STEP 2 Power Terminal Connections

To be connected using terminal lugs, rigid or flexible busbars.

	FRAME B3			FRAME B4			FRAME B5	
	125 A	160 A	200 A	250 A	315 A	400 A	500 A	630 A
Minimum cable section Cu (mm <sup>2</sup> ) at lth (IEC 60947-1)	35	35	50	95	120	185	2x95	2x120
Recommended cable section Cu (mm <sup>2</sup> ) at lth	-	-	-	-	-	-	2x30x5	2x40x5
Maximum cable section Cu (mm <sup>2</sup> )	50	95	120	150	240	240	2x185	2x300
Maximum Cu busbar width (mm)	25	25	25	32	32	32	50	50
Type of screw	M8	M8	M8	M10	M10	M10	M12	M12
Recommended tightening torque (N.m)	8.3	8.3	8.3	20	20	20	40	40
Maximum tightening torque (N.m)	13	13	13	26	26	26	45	45

Example: Control wiring for a 400VAC application having a 3 phase and neutral supply.

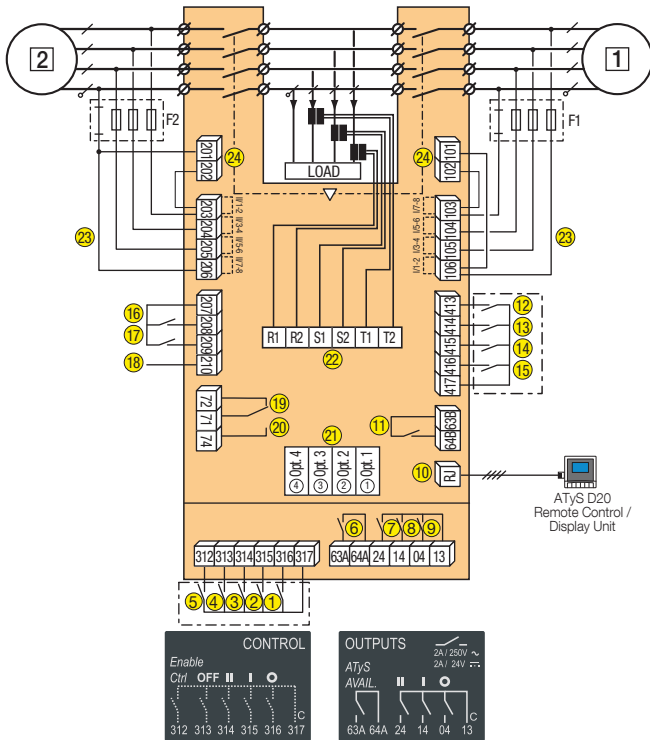

## STEP 3 CONTROL / COMMAND Terminals

Ensure that the product is in Manual Mode.

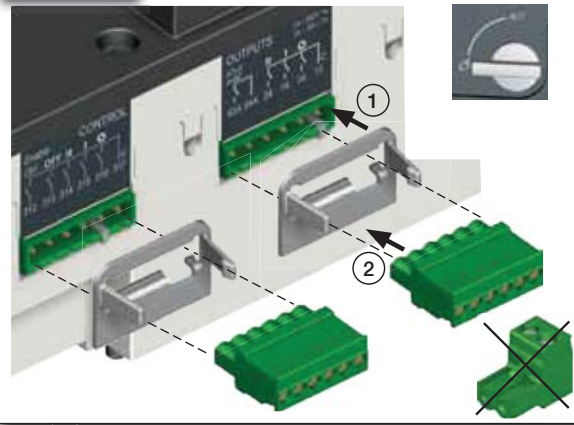

1 preferred source 2 alternate source

- Position 0 order
- Position 1 order
- Position 2 order
- Zero position priority order
- Remote Control Enable (Priority over Auto)
- Product Available output (Motor)
- Position II aux contact
- Position I aux contact
- Position 0 aux contact
- O/P to ATyS D20 remote unit
- Programmable Output Contact. By default set to ATS Product Available - Normally Open
- Programmable Inputs 1-4
- Programmable Inputs 5-6
- Aux. Supply (207/210) to be used with ATyS optional I/O modules
- Contact "Start/Stop GenSet": if S1 is not available the NC contact le contact (71-72) is close
- Contact "Start/Stop GenSet": if S1 is not available the NO contact le contact (71-74) is open
- Option Module Slots 1 to 4
- Current Transformer incoming cable connections
- Voltage Sensing Inputs
- Power Supply Inputs

# 4.1. Quick Start ATyS p Frame B3 to B5 (125 A to 630 A) continued

## STEP 5

### Check

Whilst in manual mode, check the wiring and if ok power up the product.

LED "Power" Green: ON  
LED Manual/Fault Red: ON

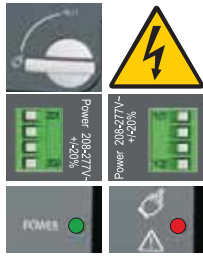

### Optional Modules

Communication between the software and the ATyS p may be done through the Ethernet/Modbus TCP or Modbus RTU modules that are available as an option. The ETHERNET / MODBUS modules are to be installed in one of the slots provided in the ATyS p ATS control unit.

Easy Config may be used with a PC connected or through ETHERNET or MODBUS modules as well as isolated from the product and simply saved on a PC for download at any convenient time.

**Note:** The ATyS p may accept a total of 4 additional Input / Output modules offering an additional 8 programmable inputs and 8 programmable outputs. When including a MODBUS module the ATyS p accepts a total of 3 I/O modules and when including the ETHERNET module a total of 2 I/O modules.

Refer to the ATyS p accessory section for details.



## STEP 6

### Programming the ATyS p

The ATyS p is to be programmed powered up and after wiring verification tests. This may either be done through the front of the ATS Controller using the keypad or with the user-friendly Easy Config software.

For convenience, we recommend to use the Easy Config software. (Downloadable free from [www.socomec.com](http://www.socomec.com)).

The ATyS p is delivered with default setting values based on most used customer application requirements. The minimum configuration parameters that must be programmed are the type of network and application together with the voltage and frequency nominal values. ATyS p Auto Configuration makes the setup of Volts, Hz, Phase rotation and Neutral Position quick and easy.

#### A - Programming with Easy Config Software

To program the ATyS p using Easy Config software simply follow the setting boxes from left to right until all desired settings in each window have been completed. Help pop ups are included to show the minimum and maximum setting values allowed. The software includes most SOCOMEC products so before programming click NEW and select the product "ATyS p" from the list of products available.

When the ATyS p is powered and communicating, the software will include a screen to monitor and display the ATyS p status.

Control through software (such as changing switch position I-O-II) is also possible when in Super User Mode.

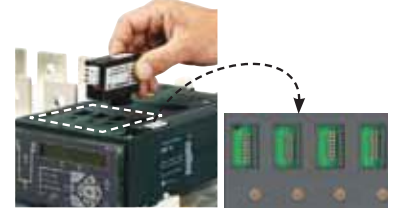

The Ethernet module includes a built in Web Server for Monitoring, Engine Exerciser Control, Events...

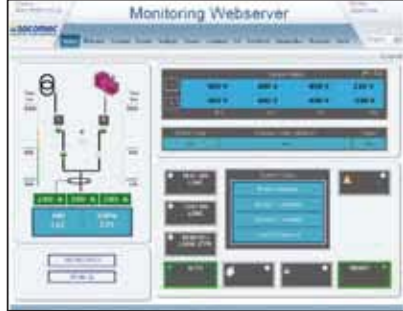

#### B - Programming with the ATyS p keypad

1 SETUP	2 VOLT. LEVELS	3 FREQ. LEVELS	4 PWR. LEVELS	5 TIMERS VALUE	6 I-O	7 COMM	8 DATE/TIME
NETWORK 4NBL	OV. U I 115%	OV. F I 105%	OV.P I 0000 KVA	1FT 0003 SEC	IN 1 --- NO	DHCP NO (9)	YEAR
AUTOCONF NO (7)	OV. U HYS I 110%	OV. F HYS I 103%	OV.P HYS I 0000 KVA	1RT 0180 SEC	IN 2 --- NO	IP 1-2 192.168.	MONTH
NEUTRAL AUTO	UND. U I 085%	UND. F I 095%	OV.P II 0000 KVA	2FT 0003 SEC	IN 3 --- NO	IP 3-4 .002.001	DAY
ROT PH. ---	UND. U HYS I 095%	UND. F HYS I 097%	OV.P HYS II 0000 KVA	2RT 0005 SEC (2)	IN 4 --- NO	GAT1-2 000.000.	HOUR
NOM. VOLT 400 V	UNB. U I 00%	OV. F II 105%	(1) When «APP» is set to «M-G»	2AT 0005 SEC (1)	IN 5 --- NO	GAT3-4 .000.000	MINUTE
NOM. FREQ 50 Hz	UNB. U HYS I 00%	OV. F HYS II 103%	(2) When «APP» is set to «M-M»	2CT 0180 SEC (1)	IN 6 --- NO	MSK1-2 255.255.	SECOND
APP M-G	OV. U II 115%	UND. F II 095%	(3) When one of the IP is set to «EON»	2ST 0030 SEC (1)	IN 7 --- NO (8)	MSK3-4 .255.000	
PRIO TON NO (1)	OV. U HYS II 110%	UND. F HYS II 097%	(4) When one of the IP is set to «EOP»	ODT 0003 SEC	IN 8 --- NO (8)	ADDRESS 005	
PRIO EON NO (3)	UND. U II 085%		(5) When one of the O/P is set to «LSC»	TOT UNL (1)	IN 9 --- NO (8)	BDRATE 9600	
PRIO NET 1 (2)	UND. U HYS II 095%		(6) When one of the O/P is set to «EES»	TOT 0010 SEC (1)	IN10 --- NO (8)	STOP BIT 1	
RETRANS NO	UNB. U II 00%		(7) If the product is in manual mode	T3T 0000 SEC (1)	IN11 --- NO (8)	PARITY NONE	
CT PRI 100	UNB. U HYS II 00%		(8) With optional I/O modules	TFT UNL (1)	IN12 --- NO (8)		
CT SEC 5			(9) With Ethernet module	TFT 0600 SEC (1)	IN13 --- NO (8)		
S1=SW2 NO				E1T 0005 SEC (3)	IN14 --- NO (8)		
BACKLGHNT INT				E2T UNL (3)	OUT 1 POP NO		
CODE P 1000				E2T 0010 SEC (3)	OUT 2 --- NO (8)		
CODE E 0000				E3T 0005 SEC (3)	OUT 3 --- NO (8)		
BACKUP SAVE				E5T 0005 SEC (4)	OUT 4 --- NO (8)		
				E6T LIM (4)	OUT 5 --- NO (8)		
				E6T 0600 SEC (4)	OUT 6 --- NO (8)		
				E7T 0005 SEC (4)	OUT 7 --- NO (8)		
				LST 0004 SEC (5)	OUT 8 --- NO (8)		
				EET 0168 H (6)	OUT 9 --- NO (8)		
				EDT 1800 SEC (6)			



ATyS p devices may also be programmed through the ATS controller keypad. This programming method is necessary for products not equipped with Ethernet or Modbus communication modules that facilitate programming through Easy Config software described above. The keypad is a useful interface and programming method most especially when changing a few parameters or simply interrogating the product.

**Programming access:** Press and hold for 5 s "Validation" push button (17). Access through the keypad is possible in Automatic or Manual mode, when the product is in a stable position (I, O or II) with at least one supply source available. Programming is not accessible whilst any cycle sequence is running.

**To change the configuration:** Enter code (factory code = 1000) using navigation push buttons (14).  
**Programming exit:** Press and hold for 5 s "Validation" push button (17).

**Note 1:** Values as listed above are the setting values by default.  
**Note 2:** Ensure that the Default Network Setting and Application match the installation or change accordingly before using Auto Configuration.

3 phase / 4 wire	3 phase / 3 wire	2 phase / 3 wire	2 phase / 2 wire	1 phase / 2 wire
4NBL 4BL	3NBL 3BL	2NBL	2BL	1BL

#### Setup by Auto Configuration

(Volts, Hz, Neutral pos., Ph rotation)

Press 5s	[Image]
Go To	1 SETUP
Scroll to	AUTOCONF
Enter code	1000
Set to	YES
Press 60 ms	[Image]
LEDs flash	[Image]
Save : press 5s	[Image]

**Note:** Source I or source II must be available to set by Auto Configuration.

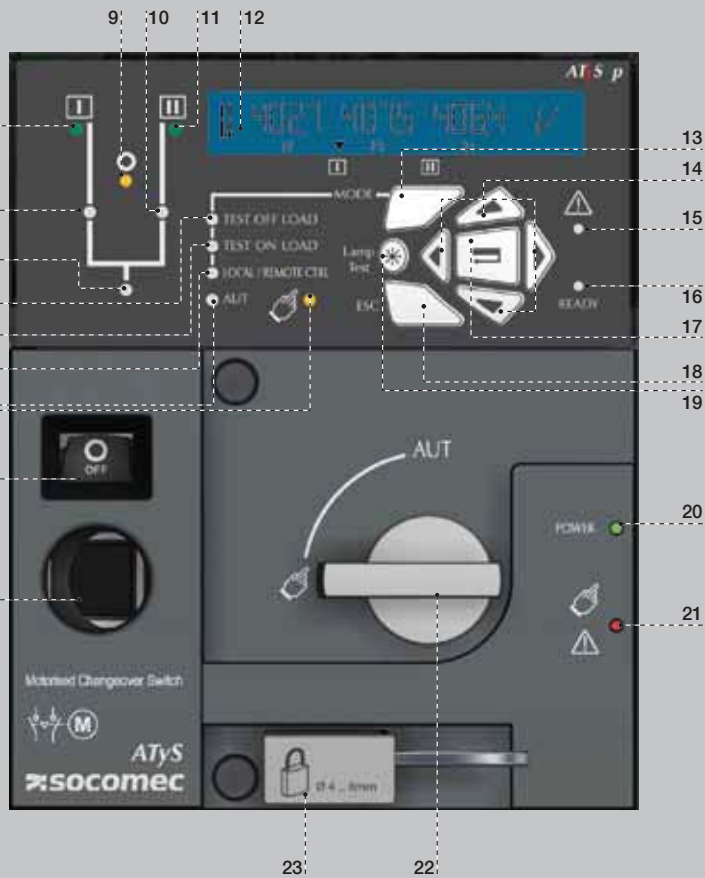

1. MANUAL Mode LED indication. (Yellow steady light when in Manual Mode).
2. AUTO Mode LED indication Green steady light when in Auto mode with no timers running. Green flashing light when in Auto with timers running.
3. LOCAL / REMOTE CONTROL Mode LED indication. Yellow steady light when in Local / Remote control mode. Remote control mode is achieved with the Auto/Manu selector switched to Auto and terminals 312 closed with terminal 317. Remote control orders are received through closing 314 to 316 with 317. REMOTE Control is also achievable through Easy Config ATyS p software when connected to the product through Ethernet or MODBUS. (Optional modules). Local Control selectable and operable through the ATyS p keypad.
4. TEST ON LOAD CONTROL Mode LED indication. (Yellow steady light when in TON/ EON mode)
5. TEST OFF LOAD CONTROL Mode LED indication. (Yellow steady light when in TOF/ EOF mode).
6. Load Supply On LED. (Green when the load is supplied).
7. Switch 1 LED position indication. (Green when in position 1).
8. Source supply I availability LED indication. (Green when supply I voltage is within the set limits).
9. Zero position LED indication. (Yellow when in position 0).
10. Switch 2 LED position indication. (Green when in position 2).
11. Source supply II availability LED indication. (Green when supply II voltage is within the set limits).
12. LCD Display Screen : (Status, measurement, timers, counters, events, faults, programming ...)
13. MODE key to shift between operation modes.
14. Navigation Keys to browse through the ATyS p menus without software.
15. FAULT LED indication. (Red steady light in case of an ATS controller internal fault. Switch the product from Auto to Manual and back to Auto to reset a fault condition).
16. READY LED indication. (Green steady light : Product is powered and in AUTO, Watchdog OK, The Product is Available to changeover).
17. Enter Key used to enter Prog Mode (Press and hold for 5 seconds) and to validate the settings programmed through the keypad.
18. ESC key used to escape from a specific screen up to the main menu.
19. Lamp test key to check the LED's and LCD screen.
20. Green LED Indication: Power
21. Red LED Indication: Product Unavailable / Manual Mode / Fault Condition
22. Auto / Manual mode selector switch (Key version available as an option)
23. Padlocking facility (Up to 3 padlocks of dia. 4 - 8mm)
24. Emergency manual operation shaft location (Accessible only in manual mode)
25. Switch position indication window: I (On switch I) 0 (Off) II (On switch II).

### STEP 7A

#### AUT Mode (Automatic Control)



Ensure that the emergency handle is not inserted in the product and turn the mode selector to the AUT position. LED "Power" Green: ON  
LED Manual/Default: OFF



### STEP 7B

#### AUT Mode (Remote Control)

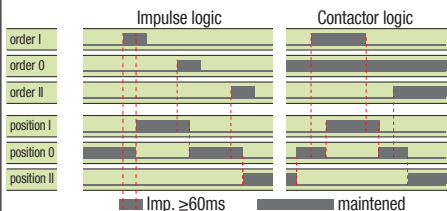

To enable control, close contact 312 with 317. For contactor logic bridge contact 316 with 317. To operate: close the contact corresponding to the desired position. To force the product to 0 position "OFF" bridge contact 313 with 317.

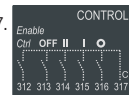

### STEP 7C

#### Manual Mode

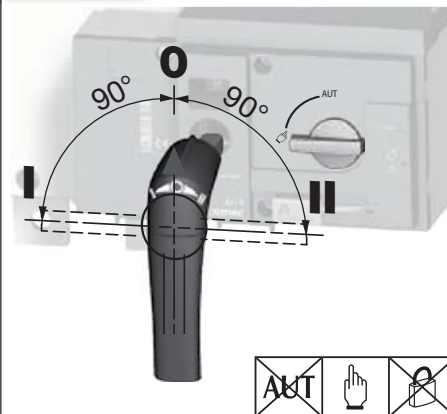

### STEP 7D

#### Padlocking Mode (as standard: in position 0)

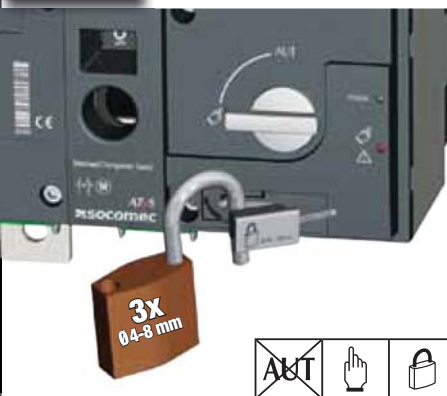

## 4.2. Quick Start ATyS p Frame B6 to B8 (800 A to 3200 A)



QUICK START EN 800A - 3200A

# ATyS p

Motorised Source Changeover Switch  
Automatic Transfer Switching Equipment

### Preliminary operations

Check the following upon delivery and after removal of the packaging:

- Packaging and contents are in good condition.
- The product reference corresponds to the order.
- Contents should include:
  - Qty 1 x ATyS p
  - Qty 1 x Emergency handle and fixing clip
  - Quick Start instruction sheet

### Warning

**⚠ Risk of electrocution, burns or injury to persons and / or damage to equipment.**

This Quick Start is intended for personnel trained in the installation and commissioning of this product. For further details refer to the product instruction manual available on the SOCOMEc website.

- This product must always be installed and commissioned by qualified and approved personnel.
- Maintenance and servicing operations should be performed by trained and authorised personnel.
- Do not handle any control or power cables connected to the product when voltage may be, or may become present on the product, directly through the mains or indirectly through external circuits.
- Always use an appropriate voltage detection device to confirm the absence of voltage.
- Ensure that no metal objects are allowed to fall in the cabinet (risk of electrical arcing).

Failure to observe good engineering practises as well as to follow these safety instructions may expose the user and others to serious injury or death.

**⚠ Risk of damaging the device**

- In case the product is dropped or damaged in any way it is recommended to replace the complete product.

### Accessories

- Bridging bars and connection kits.
- Control voltage transformer (400Vac -> 230Vac).
- DC power supply (12/24Vdc -> 230Vac).
- Mounting spacers to raise the product x 10mm.
- Phase barriers.
- Terminal shrouds / Terminal screens.
- Auxiliary contacts (Additional).
- Padlocking in 3 positions (I - 0 - II).
- Lockout accessories (RONIS - EL 11 AP).
- Door escutcheon frame.
- ATyS D20 Interface (remote control / display unit).
- RJ45 cable for ATyS D20 => ATyS p.
- Voltage sensing kit.
- Current transformers.
- Plug-in optional modules: RS485 MODBUS communication, 2 inputs/2 outputs, Ethernet communication, Ethernet communication + RS485 JBUS/MODBUS gateway, Analogue outputs, Pulse outputs.

For further details refer to the product instruction manual under chapter "Spares and Accessories"



www.socomec.com

To download, brochures, catalogues and technical manuals:  
<http://www.socomec.com/en/documentation-atys-p>

Printing informations: 1 color Black. White paper 90g/m<sup>2</sup>.  
Printing size: 420x297. Final size 210x297. This page visible first.  
CORPORATE HQ CONTACT:  
SOCOMEc SAS, 1-4 RUE DE WESTHOUSE, 67235 BENFELD, FRANCE



Non contractual document.  
Subject to change without notice.

542 000 F - 10/16 - EN

## Installation and Commissioning

**STEP 1**  
Cabinet / Back Plate Installation

**STEP 2**  
Power Terminal Connections

**STEP 3**  
COMMAND / CONTROL terminal connections

**STEP 4**  
Power SUPPLY and ATS Controller Terminal Connections

**STEP 5**  
CHECK

**STEP 6**  
PROGRAMMING  
A - Software  
B - Keypad

**STEP 7A**  
AUT Mode  
(Automatic Control)

**STEP 7B**  
AUT Mode  
(Remote Control)

**STEP 7C**  
Manual Mode

**STEP 7D**  
Padlocking Mode

### STEP 4

#### Power Supply, Sensing and Control wiring (ATS Controller)

Connect the product with a cable of section of 1,5 to 2,5 mm<sup>2</sup>.  
Screw M3 - Tightening torque: min.: 0.5 Nm - max.: 0.6 Nm

**ATS Power Supply Input II**  
Power supply II - L/N  
Power supply II - N/L  
208-277 VAC ±20%:  
50/60 Hz

**ATS Voltage Sensing Input Source supply II**  
S II - Phase / Neutral  
S II - Phase  
S II - Phase  
575 VAC (ph-ph) max  
S II - Neutral / Phase  
332 VAC (ph-n) max

**Programmable Inputs**  
To opt. Module/Common  
Progr. Inputs (208-209)  
To opt. Module positive

**Genset Start/Stop Signal**  
NC  
Common  
NO

Power 208/277V ~ 50/60 Hz  
Voltage sensing switch II  
Voltage sensing switch I  
Current Transformer incoming cable connections  
Slots for optional modules  
See on the back "Optional modules"

**ATS Power Supply Input I**  
Power supply I - L/N  
Power supply I - N/L  
208-277 VAC ±20%:  
50/60 Hz

**ATS Voltage Sensing Input Source supply I**  
S I - Phase / Neutral  
S I - Phase  
S I - Phase  
575 VAC (ph-ph) max  
S I - Neutral / Phase  
332 VAC (ph-n) max

**ATS Module Control Inputs (Programmable)**

**ATS Module Output Contact (Programmable)**

**Remote interface RJ45 - to ATyS D20**

Recommended to use SOCOMEc Voltage Sensing Kit (refer to ATyS p accessories for details)

# STEP 1

## Installation

Caution: Ensure that the product is installed on a flat rigid surface.

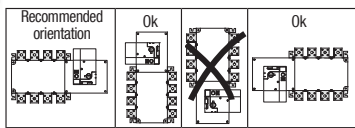

Door cut-out for front panel.

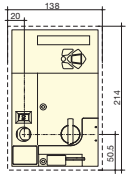

ATyS p 800 to 1000 A

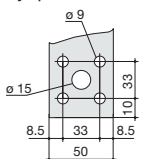

ATyS p 1250 A

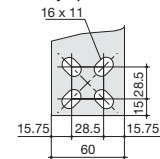

ATyS p 1600 to 3200 A

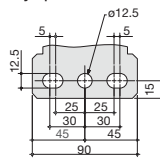

ATyS p 800 to 1600 A

ATyS p 2000 to 3200 A

Dimensions in mm.

	800 A		1000 A		1250 A		1600 A		2000 A		2500 A		3200 A	
	3 P	4 P	3 P	4 P	3 P	4 P	3 P	4 P	3 P	4 P	3 P	4 P	3 P	4 P
<b>M</b>	255	335	255	335	255	335	347	467	347	467	347	467	347	467
<b>T</b>	80	80	80	80	80	80	120	120	120	120	120	120	120	120
<b>C</b>	391	391	391	391	391	391	391	391	523	523	523	523	523	523

# STEP 2

## Power Terminal Connections

To be connected using terminal lugs, rigid or flexible busbars.

	FRAME B6			FRAME B7	FRAME B8		
	800 A	1000 A	1250 A	1600 A	2000 A	2500 A	3200 A
Minimum cable section Cu (mm <sup>2</sup> ) at lth (IEC 60947-1)	2x185	-	-	-	-	-	-
Recommended cable section Cu (mm <sup>2</sup> ) at lth	2x50x5	2x60x5	2x60x7	2x100x5	3x100x5	4x100x5	3x100x10
Maximum cable section Cu (mm <sup>2</sup> )	2x300	4x185	4x185	6x185	-	-	-
Maximum Cu busbar width (mm)	63	63	63	100	100	100	100
Type of screw	M8	M8	M10	M12	M12	M12	M12
Recommended tightening torque (N.m)	8.3	8.3	20	40	40	40	40
Maximum tightening torque (N.m)	13	13	26	45	45	45	45

Example: Control wiring for a 400VAC application having a 3 phase and neutral supply.

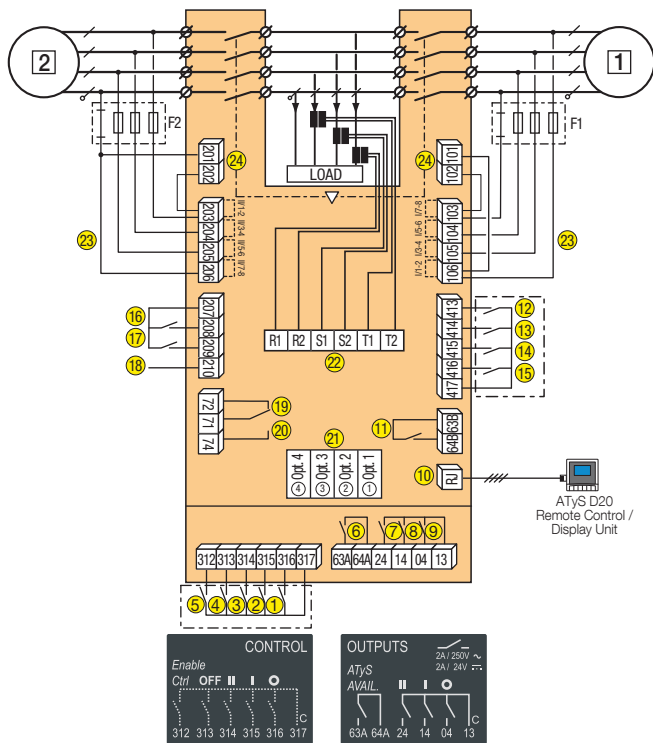

# STEP 3

## CONTROL / COMMAND Terminals

Ensure that the product is in Manual Mode.

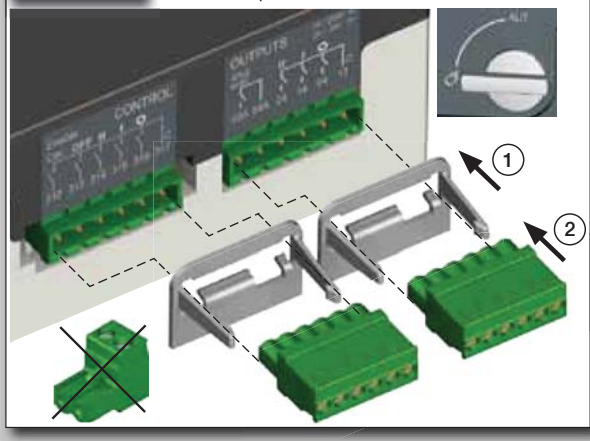

- 1. preferred source 2. alternate source
- 1. Position 0 order
- 2. Position 1 order
- 3. Position 2 order
- 4. Zero position priority order
- 5. Remote Control Enable (Priority over Auto)
- 6. Product Available output (Motor)
- 7. Position II aux contact
- 8. Position I aux contact
- 9. Position 0 aux contact
- 10. O/P to ATyS D20 remote unit
- 11. Programmable Output Contact. By default set to ATS Product Available - Normally Open
- 12-15. Programmable Inputs 1-4
- 16-17. Programmable Inputs 5-6
- 18. Aux. Supply (207/210) to be used with ATyS optional I/O modules
- 19. Contact "Start/Stop Genset": if S1 is not available the NC contact le contact (71-72) is close
- 20. Contact "Start/Stop Genset": if S1 is not available the NO contact le contact (71-74) is open
- 21. Option Module Slots 1 to 4
- 22. Current Transformer incoming cable connections
- 23. Voltage Sensing Inputs
- 24. Power Supply Inputs

## «4.2. Quick Start ATyS p Frame B6 to B8 (800 A to 3200 A)» continued

### STEP 5

#### Check

Whilst in manual mode, check the wiring and if ok power up the product.

LED "Power" Green: ON  
LED Manual/Fault Red: ON

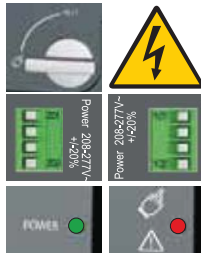

#### Optional Modules

Communication between the software and the ATyS p may be done through the Ethernet/Modbus TCP or Modbus RTU modules that are available as an option. The ETHERNET / MODBUS modules are to be installed in one of the slots provided in the ATyS p ATS control unit.

Easy Config may be used with a PC connected or through ETHERNET or MODBUS modules as well as isolated from the product and simply saved on a PC for download at any convenient time.

**Note:** The ATyS p may accept a total of 4 additional Input / Output modules offering an additional 8 programmable inputs and 8 programmable outputs. When including a MODBUS module the ATyS p accepts a total of 3 I/O modules and when including the ETHERNET module a total of 2 I/O modules.

Refer to the ATyS p accessory section for details.

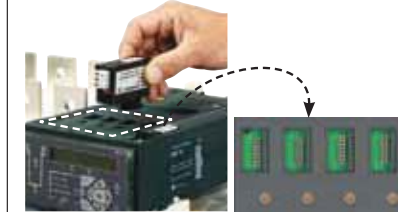

The Ethernet module includes a built in Web Server for Monitoring, Engine Exerciser Control, Events...

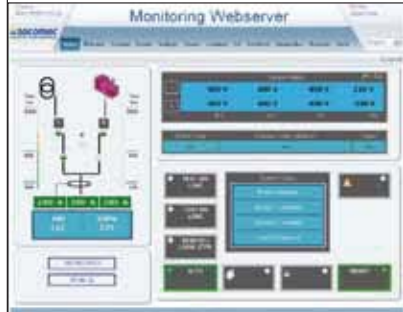

### STEP 6

#### Programming the ATyS p

The ATyS p is to be programmed powered up and after wiring verification tests. This may either be done through the front of the ATS Controller using the keypad or with the user-friendly Easy Config software.

For convenience, we recommend to use the Easy Config software. (Downloadable free from [www.socomec.com](http://www.socomec.com)).

The ATyS p is delivered with default setting values based on most used customer application requirements. The minimum configuration parameters that must be programmed are the type of network and application together with the voltage and frequency nominal values. ATyS p Auto Configuration makes the setup of Volts, Hz, Phase rotation and Neutral Position quick and easy.

#### A - Programming with Easy Config Software

To program the ATyS p using Easy Config software simply follow the setting boxes from left to right until all desired settings in each window have been completed. Help pop ups are included to show the minimum and maximum setting values allowed. The software includes most SOCOMEC products so before programming click NEW and select the product "ATyS p" from the list of products available.

When the ATyS p is powered and communicating, the software will include a screen to monitor and display the ATyS p status.

Control through software (such as changing switch position I-O-II) is also possible when in Super User Mode.



#### B - Programming with the ATyS p keypad

1 SETUP	2 VOLT. LEVELS	3 FREQ. LEVELS	4 PWR. LEVELS	5 TIMERS VALUE	6 I-O	7 COMM	8 DATE/TIME
NETWORK 4NBL	OV. U I 115%	OV. F I 105%	OV.P I 0000 KVA	1FT 0003 SEC	IN 1 --- NO	DHCP NO (9)	YEAR
AUTOCONF NO (7)	OV. U HYS I 110%	OV. F HYS I 103%	OV.P HYS I 0000 KVA	1RT 0180 SEC	IN 2 --- NO	IP 1-2 192.168.	MONTH
NEUTRAL AUTO	UND. U I 085%	UND. F I 095%	OV.P II 0000 KVA	2FT 0003 SEC	IN 3 --- NO	IP 3-4 .002.001	DAY
ROT PH. ---	UND. U HYS I 095%	UND. F HYS I 097%	OV.P HYS II 0000 KVA	2RT 0005 SEC (2)	IN 4 --- NO	GAT1-2 000.000.	HOUR
NOM. VOLT 400 V	UNB. U I 00%	OV. F II 105%	(1) When «APP» is set to «M-G»	2AT 0005 SEC (1)	IN 5 --- NO	GAT3-4 .000.000	MINUTE
NOM. FREQ 50 Hz	UNB. U HYS I 00%	OV. F HYS II 103%	(2) When «APP» is set to «M-M»	2CT 0180 SEC (1)	IN 6 --- NO	MSK1-2 255.255.	SECOND
APP M-G	OV. U II 115%	UND. F II 095%	(3) When one of the IP is set to «EON»	2ST 0030 SEC (1)	IN 7 --- NO (8)	MSK3-4 .255.000	
PRIO TON NO (1)	OV. U HYS II 110%	UND. F HYS II 097%	(4) When one of the IP is set to «EOP»	ODT 0003 SEC	IN 8 --- NO (8)	ADDRESS 005	
PRIO EON NO (3)	UND. U II 085%		(5) When one of the O/P is set to «LSC»	TOT UNL (1)	IN 9 --- NO (8)	BDRATE 9600	
PRIO NET 1 (2)	UND. U HYS II 095%		(6) When one of the O/P is set to «EES»	TOT 0010 SEC (1)	IN10 --- NO (8)	STOP BIT 1	
RETRANS NO	UNB. U II 00%		(7) If the product is in manual mode	T3T 0000 SEC (1)	IN11 --- NO (8)	PARITY NONE	
CT PRI 100	UNB. U HYS II 00%		(8) With optional I/O modules	TFT UNL (1)	IN12 --- NO (8)		
CT SEC 5			(9) With Ethernet module	TFT 0600 SEC (1)	IN13 --- NO (8)		
S1=SW2 NO				E1T 0005 SEC (3)	IN14 --- NO (8)		
BACKLGHNT INT				E2T UNL (3)	OUT 1 POP NO		
CODE P 1000				E2T 0010 SEC (3)	OUT 2 --- NO (8)		
CODE E 0000				E3T 0005 SEC (3)	OUT 3 --- NO (8)		
BACKUP SAVE				E5T 0005 SEC (4)	OUT 4 --- NO (8)		
				E6T LIM (4)	OUT 5 --- NO (8)		
				E6T 0600 SEC (4)	OUT 6 --- NO (8)		
				E7T 0005 SEC (4)	OUT 7 --- NO (8)		
				LST 0004 SEC (5)	OUT 8 --- NO (8)		
				EET 0168 H (6)	OUT 9 --- NO (8)		
				EDT 1800 SEC (6)			



ATyS p devices may also be programmed through the ATS controller keypad. This programming method is necessary for products not equipped with Ethernet or Modbus communication modules that facilitate programming through Easy Config software described above. The keypad is a useful interface and programming method most especially when changing a few parameters or simply interrogating the product.

**Programming access:** Press and hold for 5 s "Validation" push button (17). Access through the keypad is possible in Automatic or Manual mode, when the product is in a stable position (I, O or II) with at least one supply source available. Programming is not accessible whilst any cycle sequence is running.

**To change the configuration:** Enter code (factory code = 1000) using navigation push buttons (14).

**Programming exit:** Press and hold for 5 s "Validation" push button (17).

**Note 1:** Values as listed above are the setting values by default.

**Note 2:** Ensure that the Default Network Setting and Application match the installation or change accordingly before using Auto Configuration.

3 phase / 4 wire	3 phase / 3 wire	2 phase / 3 wire	2 phase / 2 wire	1 phase / 2 wire
4NBL 4BL	3NBL 3BL	2NBL	2BL	1BL

#### Setup by Auto Configuration

(Volts, Hz, Neutral pos., Ph rotation)

Press 5s	[Image of button]
Go To	1 SETUP
Scroll to	AUTOCONF
Enter code	1000
Set to	YES
Press 60 ms	[Image of button]
LEDs flash	[Image of LEDs]
Save : press 5s	[Image of button]

**Note:** Source I or source II must be available to set by Auto Configuration.

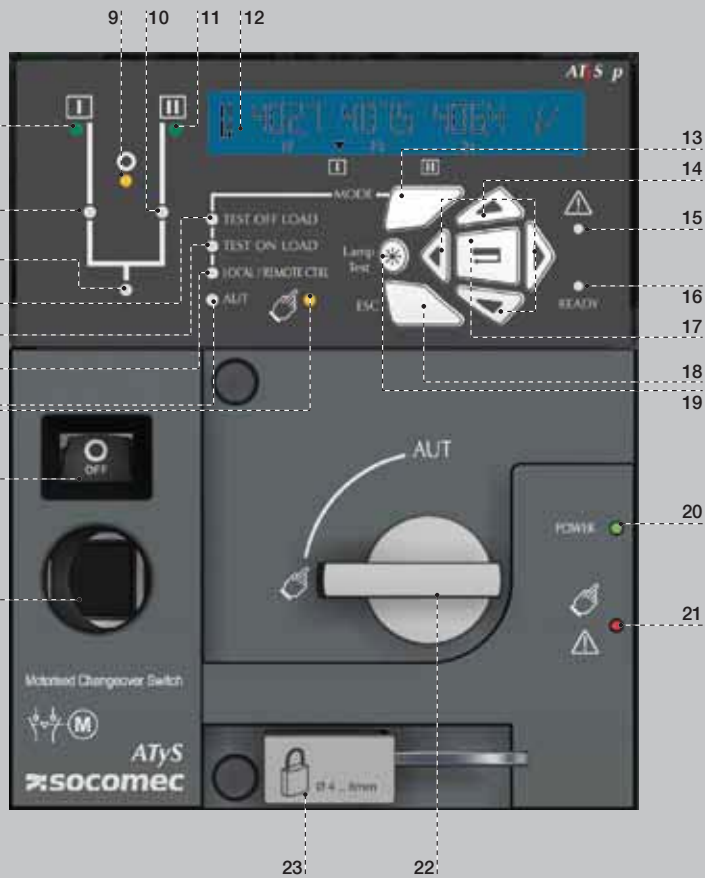

1. MANUAL Mode LED indication. (Yellow steady light when in Manual Mode).
2. AUTO Mode LED indication Green steady light when in Auto mode with no timers running. Green flashing light when in Auto with timers running.
3. LOCAL / REMOTE CONTROL Mode LED indication. Yellow steady light when in Local / Remote control mode. Remote control mode is achieved with the Auto/Manu selector switched to Auto and terminals 312 closed with terminal 317. Remote control orders are received through closing 314 to 316 with 317. REMOTE Control is also achievable through Easy Config ATyS p software when connected to the product through Ethernet or MODBUS. (Optional modules). Local Control selectable and operable through the ATyS p keypad.
4. TEST ON LOAD CONTROL Mode LED indication. (Yellow steady light when in TON/ EON mode)
5. TEST OFF LOAD CONTROL Mode LED indication. (Yellow steady light when in TOF/ EOF mode).
6. Load Supply On LED. (Green when the load is supplied).
7. Switch 1 LED position indication. (Green when in position 1).
8. Source supply I availability LED indication. (Green when supply I voltage is within the set limits).
9. Zero position LED indication. (Yellow when in position 0).
10. Switch 2 LED position indication. (Green when in position 2).
11. Source supply II availability LED indication. (Green when supply II voltage is within the set limits).
12. LCD Display Screen : (Status, measurement, timers, counters, events, faults, programming ....)
13. MODE key to shift between operation modes.
14. Navigation Keys to browse through the ATyS p menus without software.
15. FAULT LED indication. (Red steady light in case of an ATS controller internal fault. Switch the product from Auto to Manual and back to Auto to reset a fault condition).
16. READY LED indication. (Green steady light : Product is powered and in AUTO, Watchdog OK, The Product is Available to changeover).
17. Enter Key used to enter Prog Mode (Press and hold for 5 seconds) and to validate the settings programmed through the keypad.
18. ESC key used to escape from a specific screen up to the main menu.
19. Lamp test key to check the LED's and LCD screen.
20. Green LED Indication: Power
21. Red LED Indication: Product Unavailable / Manual Mode / Fault Condition
22. Auto / Manual mode selector switch (Key version available as an option)
23. Padlocking facility (Up to 3 padlocks of dia. 4 - 8mm)
24. Emergency manual operation shaft location (Accessible only in manual mode)
25. Switch position indication window: I (On switch I) O (Off) II (On switch II).

### STEP 7A

#### AUT Mode (Automatic Control)



Ensure that the emergency handle is not inserted in the product and turn the mode selector to the AUT position. LED "Power" Green: ON LED Manual/Default: OFF



### STEP 7B

#### AUT Mode (Remote Control)

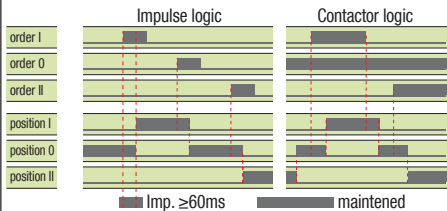

To enable control, close contact 312 with 317. For contactor logic bridge contact 316 with 317. To operate: close the contact corresponding to the desired position. To force the product to 0 position "OFF" bridge contact 313 with 317.

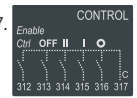

### STEP 7C

#### Manual Mode

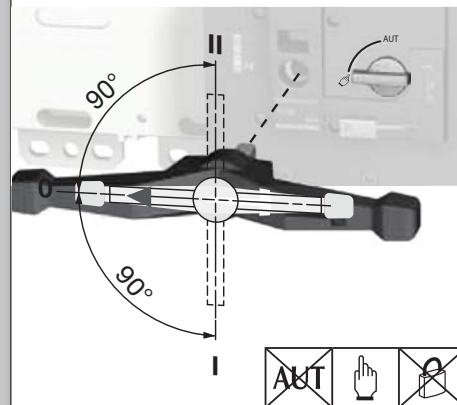

### STEP 7D

#### Padlocking Mode (as standard: in position 0)

